

Linea™ SWIR 1k

SL-GA-01K04A-00-R InGaAs Line Scan Camera

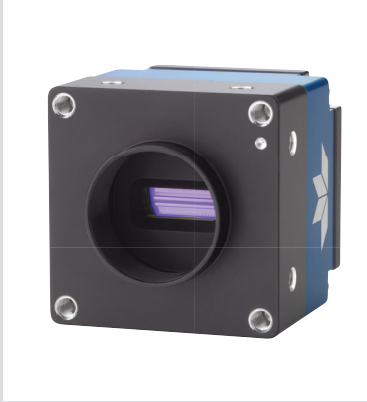

Key Features

- » 1024 pixel resolution
- » 12.5 µm pixel size
- » 950 to 1700 nm spectral band
- » 40 kHz line rate
- » HDR mode
- » Cycling mode
- » Programmable I/Os
- » Compact form factor
- » Configurable full well
- » GigE, PoE

Typical Applications

- » Food sorting
- » Industrial sorting
- » Recycling
- » Solar panel inspection
- » Silicon wafer inspection
- » General purpose machine vision

GigE SWIR Line Scan Camera

Teledyne DALSA's 1024 pixel GigE SWIR line scan camera features a cutting-edge InGaAs sensor in a compact package for a wide variety of machine vision applications.

This high speed, high resolution camera is the first product in DALSA's SWIR family. The uncooled sensor delivers exceptional responsivity that can be further improved through horizontal pixel binning. Alternatively, digital binning gives customers the option to bin to 512 pixel resolution with 25 µm pixels.

The newest member of the Linea family features an advanced InGaAs detector with 12.5 µm pixels in a 1k array that offers a 40 kHz line rate. The small pixels offer high resolution without compromising sensitivity. With high speed, high sensitivity, cycling mode, and programmable I/Os, the versatile Linea SWIR is ideal for applications such as optical sorting, solar panel inspection, and general purpose machine vision.

Specifications

Resolution	1024 pixels			
Line Rate	40 kHz			
Pixel Pitch	12.5 µm			
Spectral Band	950 to 1700 nm			
Gain Setting	1	2	3	4
Max Responsivity (DN12/nJ/cm ² at 1527 nm)	10	100	400	800
Dark Noise (DN12)	0.7	2.1	7.3	13
Full Well (ke-)	10,000	1,000	250	140
Dynamic Range (dB)	74.2	64.2	53.2	48.4
Peak Quantum Efficiency	66%			
Dark Current	< 5 pA			
Output Bit Depth	8, 12 bit mono			
Optical Interface	C Mount			
Control & Data	GigE			
GPIO	Programmable: 2 inputs, 2 outputs			
Camera Size	46 x 46 x 55 mm			
Camera Weight	< 208 g			

SPECIFICATIONS

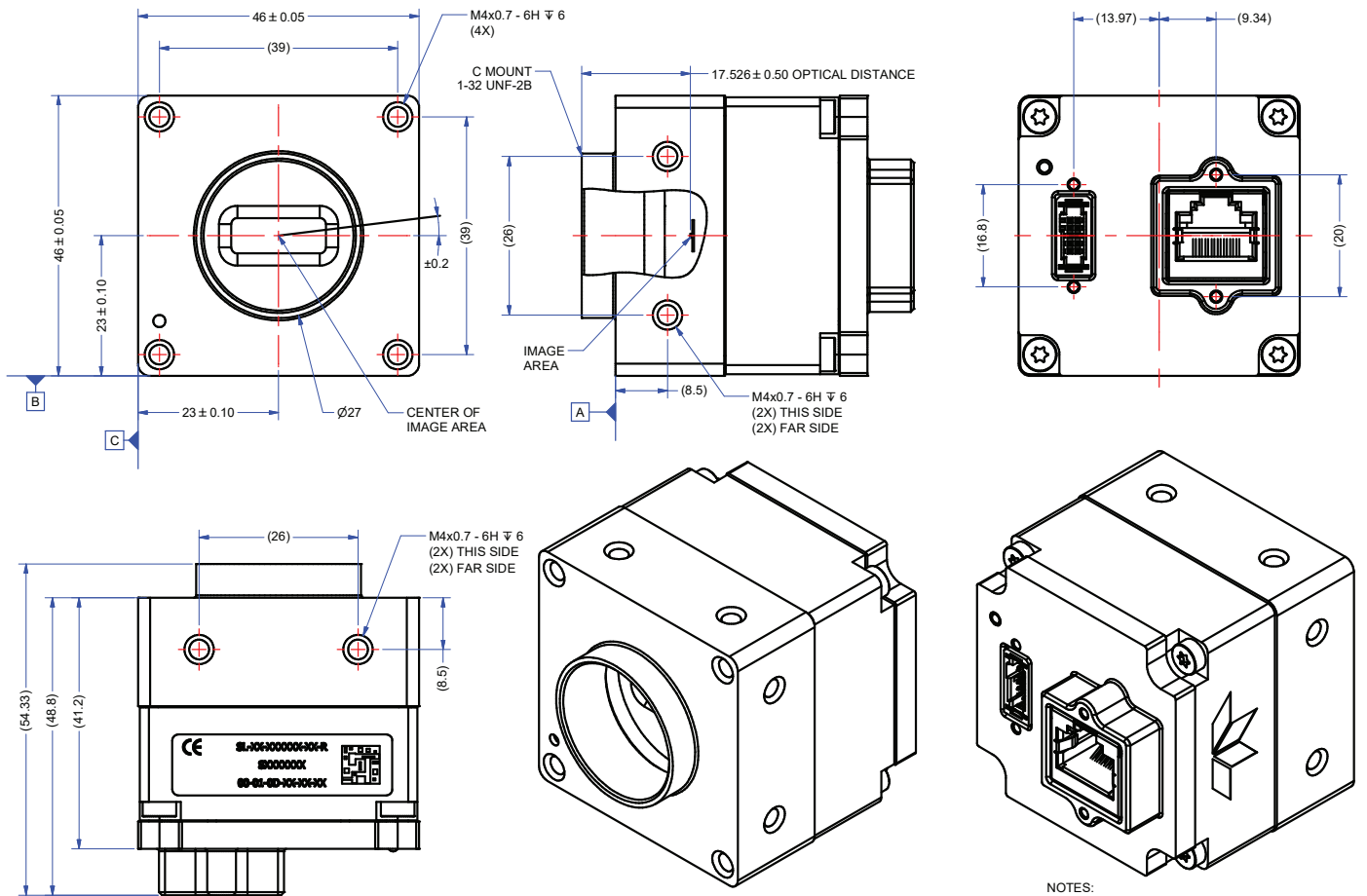
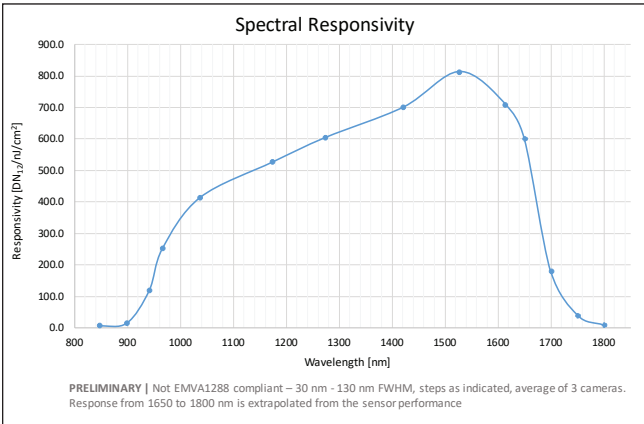

NOTES:
1. UNITS: MILLIMETERS.
2. IMAGE AREA IS ALIGNED TO DATUMS **A**, **B** & **C**

Americas
Boston, USA
+1 978-670-2000
sales.americas@teledynedalsa.com

Europe
Krailling, Germany
+49 89-89-54-57-3-80
sales.europe@teledynedalsa.com

Asia Pacific
Tokyo, Japan
+81 3-5960-6353
sales.asia@teledynedalsa.com

Shanghai, China
+86 21-3368-0027
sales.asia@teledynedalsa.com

PRELIMINARY

Teledyne DALSA has its corporate offices in Waterloo, Canada. Teledyne DALSA reserves the right to make changes at any time without notice. © Teledyne DALSA. Revision Date: 20191211

www.adept.net.au